

Unità Aggregata / Aggregate Unit : **Fast Line ONE ER32 H100**
 Codice / Code : **FL.ONE.00/100CI30-H1**

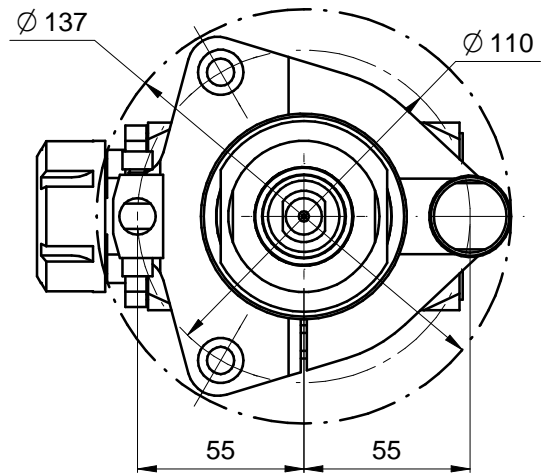
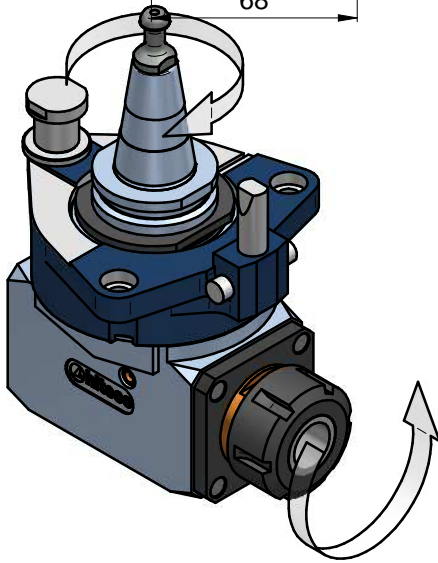
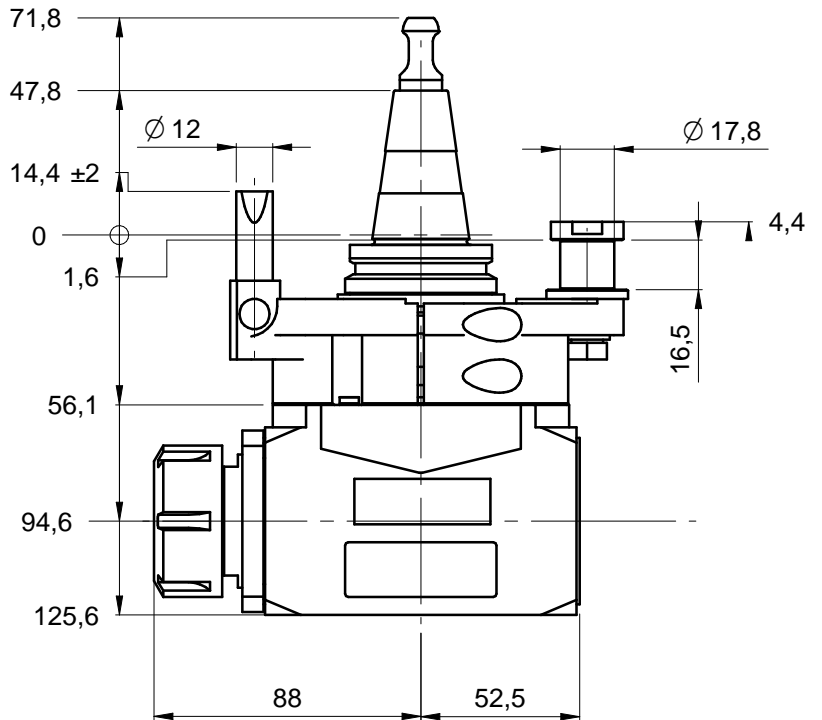
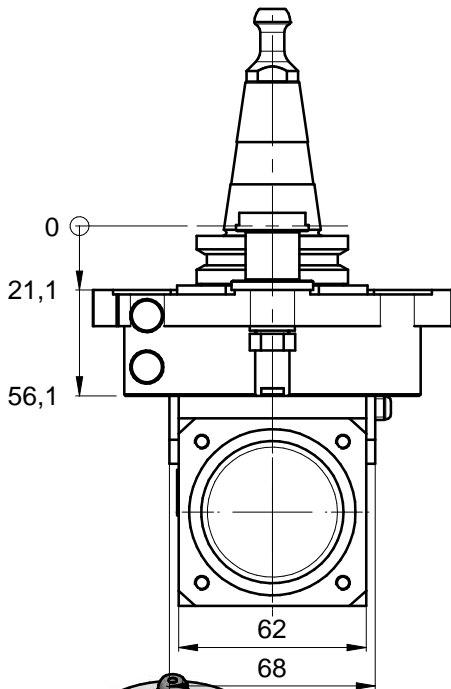

Specifiche tecniche / Technical specifications

Attacco mandrino / Spindle coupling	ISO30
Velocità rotazione mandrino/ Spindle speed	10850 rpm max *
Velocità rotazione utensile / Tool speed	15500 rpm max *
Senso rotazione mandrino - Spindle rotation direction	VEDI DISEGNO - See drawing
Possibilità inversione rotazione mandrino - Possibility to change electrospindle direction	NO
Rapporto di trasmissione / Gear ratio	1:1.43
Attacco utensile / Tool coupling	ER32DX
Diametro codolo / Tool shank diameter	2-20
Diametro lama / Blade diameter	/
Diametro foro lama / Hole blade diameter	/
Peso / Weight	4.2 kg
Lubrificazione / Lubrication	Grease KLUEBER NBU15
Temperatura / Temperature	75 °C / 167 F max
Orientamento angolare / aggregate rotation	0-360° continuo/continuous
Connessione asse C / C axis connection type	HIT1

* vedere manuale / see user manual

** Il diametro massimo dipende dalla posizione della flangia di riferimento /max blade diameter depends on pin-plate angular position